

1a Look at the pictures. What can you see? Write two words from the box for each picture.

clap costume desk graduation mask principal game violin

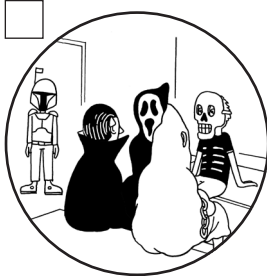

.....
.....

.....
.....

.....
.....

.....
.....

1b Guess the correct order of the pictures. After you read the story, check your ideas.

2 Do the crossword.

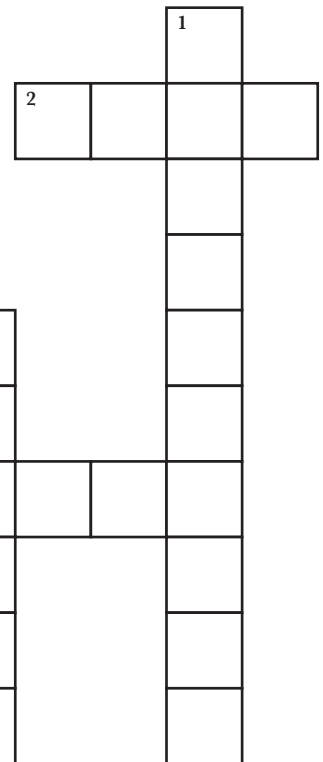
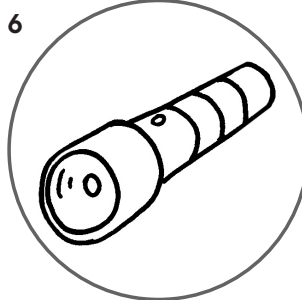

Across

- 2 a stupid person
- 6 a small light; you can hold it

Down

- 1 the last day of school; a special day
- 3 a small thing that people wear in their ear – it helps them hear better (two words)
- 4 the most important teacher in a school
- 5 to speak very quietly

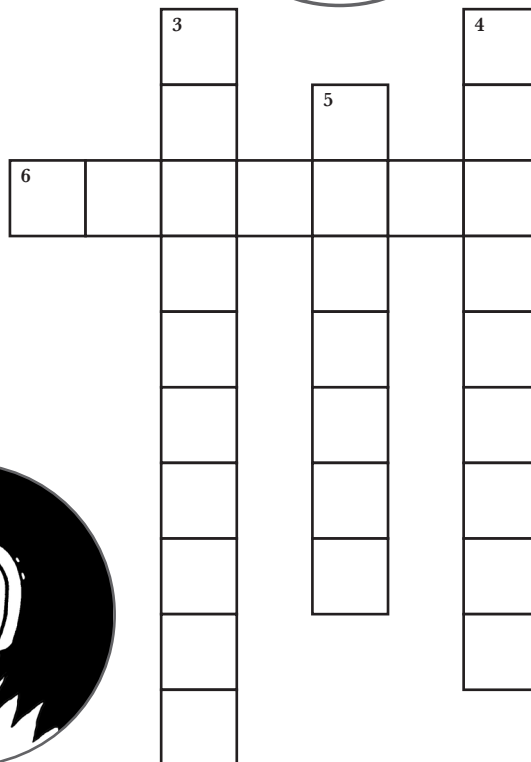
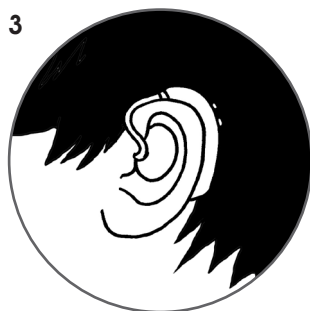

3 Look at the pictures. Write comparative and superlative sentences about the characters. Use the words in the box.

bad cool cruel friendly funny good happy
kind old short strong stupid tall



August

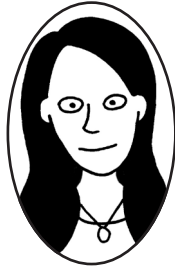

Via



Justin



Julian



Miranda



Summer

August is friendlier than Julian.

1

2

3

4

5

6

4 Put the events in the correct order (1–5).

- a August starts getting horrible notes from other kids at school.
- b Julian says that August doesn't need a mask – he looks horrible without one.
- c A boy from another school hurts August arm while he's at camp.
- d Julian calls August a 'freak' (so Jack hits him).
- e Nobody wants to sit by August in the cafeteria.

5 Complete the chart about the story.

Who are the most important people?

.....

.....

.....

.....

What happens?

.....

.....

.....

.....

.....

.....

Where does it happen?

.....

.....

.....

.....

.....

.....

What is the problem?

.....

.....

.....

.....

How do people make things better?

.....

.....

.....

.....

